

THIS DRAWING IS UNPUBLISHED. RELEASED FOR PUBLICATION  
 © COPYRIGHT BY TYCO ELECTRONICS CORPORATION. ALL RIGHTS RESERVED.

LOC		DIST		REVISIONS			
P	LTR	DESCRIPTION		DATE	DWN	APVD	
CM	00	H		EC 0G3B 0214 05	25AUG05	BSV	CJ

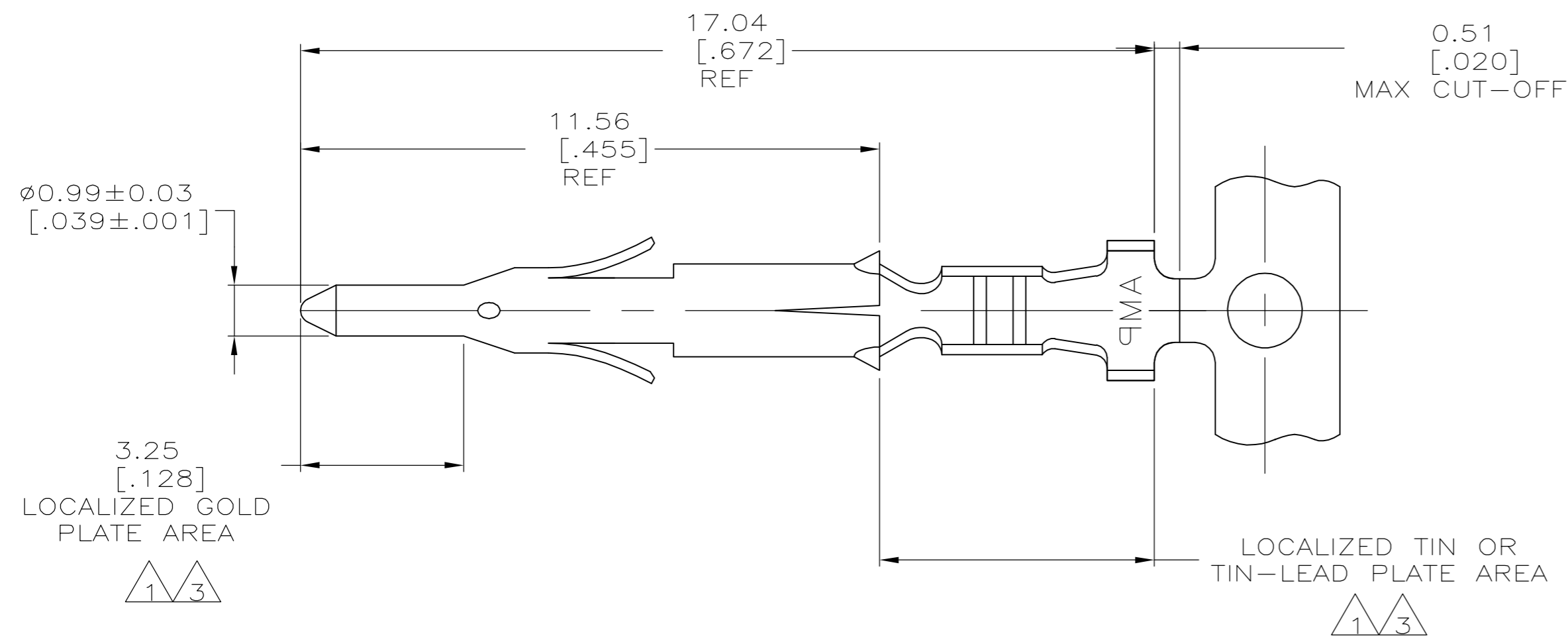

- 1. 0.00076 [.000030] MIN GOLD IN LOCALIZED GOLD PLATE AREA AND 0.00254 [.000100] MIN BRIGHT TIN-LEAD IN LOCALIZED TIN-LEAD PLATE AREA OVER 0.0013 [.000050] MIN NICKEL.
- 2. WIRE RANGE: 0.5 - 0.15mm<sup>2</sup> (30-26 AWG).
- 3. 0.00076 [.000030] MIN GOLD IN LOCALIZED GOLD PLATE AREA AND 0.00254 [.000100] MIN MATTE TIN IN LOCALIZED TIN PLATE AREA OVER 0.0013 [.000050] MIN NICKEL.

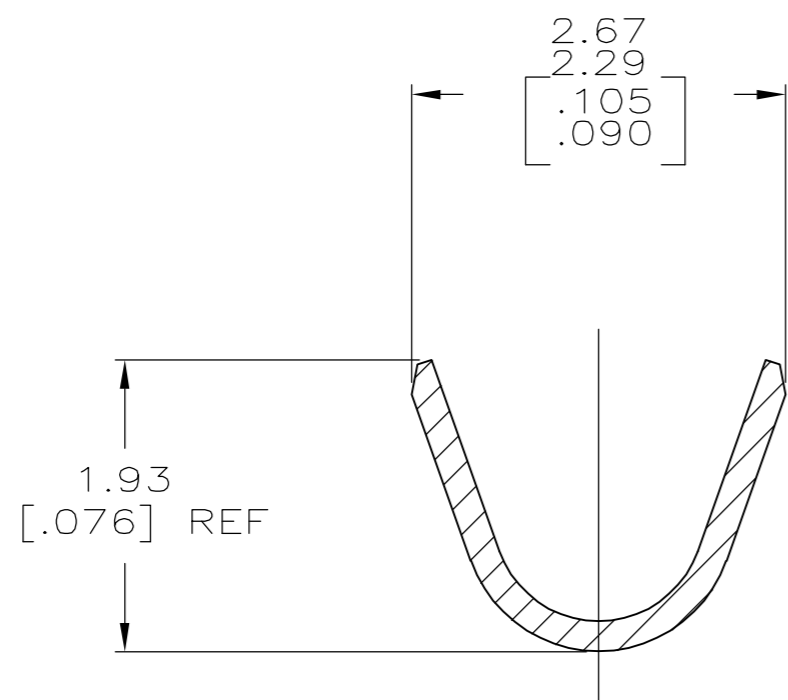
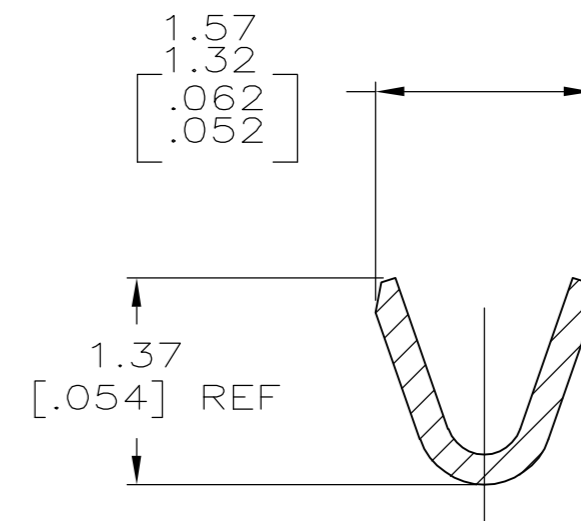
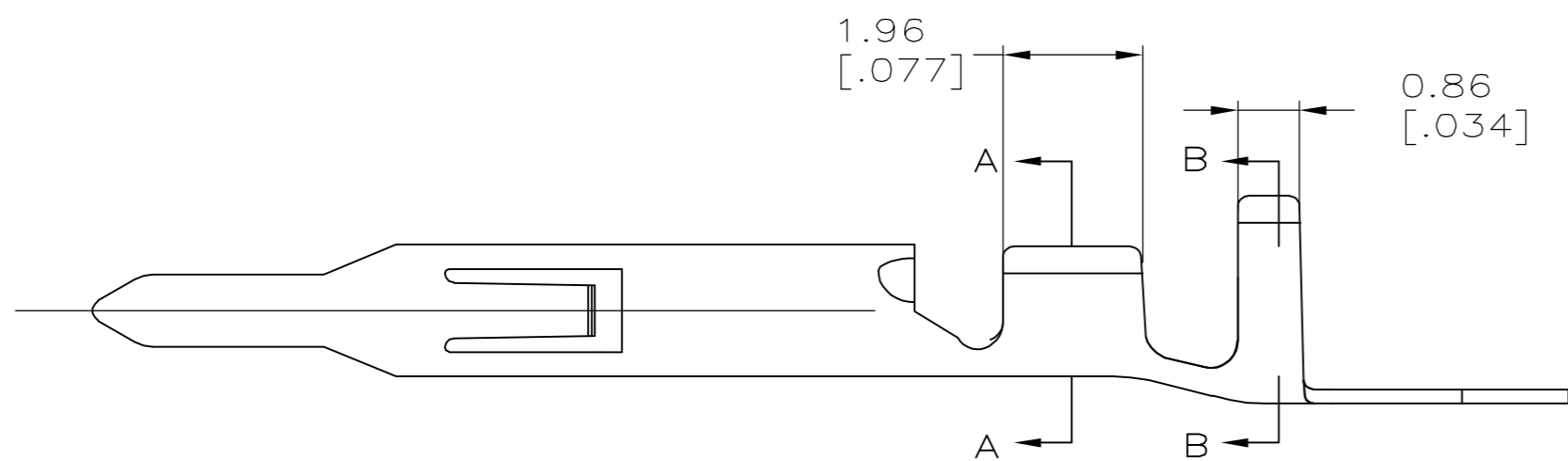

3	0.20 [.008] BRASS	1-770835-0
1	0.20 [.008] BRASS	770835-3
PRE-TIN	0.20 [.008] BRASS	770835-1
FINISH	MATERIAL	PART NUMBER

THIS DRAWING IS A CONTROLLED DOCUMENT.		DWN S. HOOVER 05MAR03	Tyco Electronics Corporation	
DIMENSIONS: mm [INCHES]		CHK C. JONES 05MAR03	Harrisburg, PA 17105-3608	
TOLERANCES UNLESS OTHERWISE SPECIFIED:		APVD C. JONES 05MAR03	NAME	
0 PLC ± -	1 PLC ± -	PRODUCT SPEC	PIN	
2 PLC ± 0.13[.005]	3 PLC ± -	APPLICATION SPEC	MINI UNIVERSAL MATE-N-LOK(TM)	
4 PLC ± -	ANGLES ± -	WEIGHT -	SIZE A2	CAGE CODE 00779
MATERIAL -	FINISH -	CUSTOMER DRAWING	DRAWING NO C=770835	RESTRICTED TO -
			SCALE 10:1	SHEET 1 of 1
			REV H	

METRIC